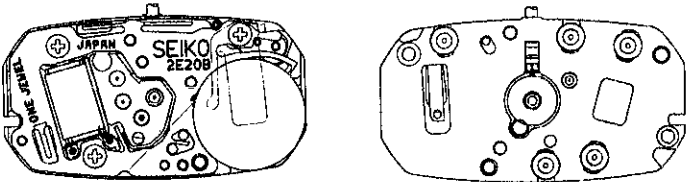

PARTS CATALOGUE/TECHNICAL GUIDE

Cal. 2E20B

[SPECIFICATIONS]

Item		Cal. No.	2E20B
Movement		 <p>(x 2.0)</p>	
Movement size	Outside diameter	15.5 mm between 6 o'clock and 12 o'clock sides 8.4 mm between 3 o'clock and 9 o'clock sides	
	Casing diameter	15.1 mm between 6 o'clock and 12 o'clock sides	
	Height	2.2 mm	
Time indication		2 hands (Move at 20-second intervals)	
Driving system		Step motor (Fixed-width pulse system)	
Additional mechanism		<ul style="list-style-type: none"> • Train wheel setting device • Electronic circuit reset switch 	
Loss/gain		Monthly rate at normal temperature range: less than 15 seconds	
Regulation system		Nil	
Measuring gate by quartz tester		Use 10-second gate.	
Battery		SEIKO SR521SW, Maxell SR521SW, SONY SR521SW Battery life is approximately 3 years. Voltage: 1.55V	
Jewels		1 jewel	

PARTS CATALOGUE

Cal. 2E20B

Disassembling procedures Figs.: ① → ③①

Reassembling procedures Figs.: ③① → ①

Lubricating: Types of oil

● Moebius A

○ SEIKO Watch Oil S-6

Oil quantity

○ Normal quantity

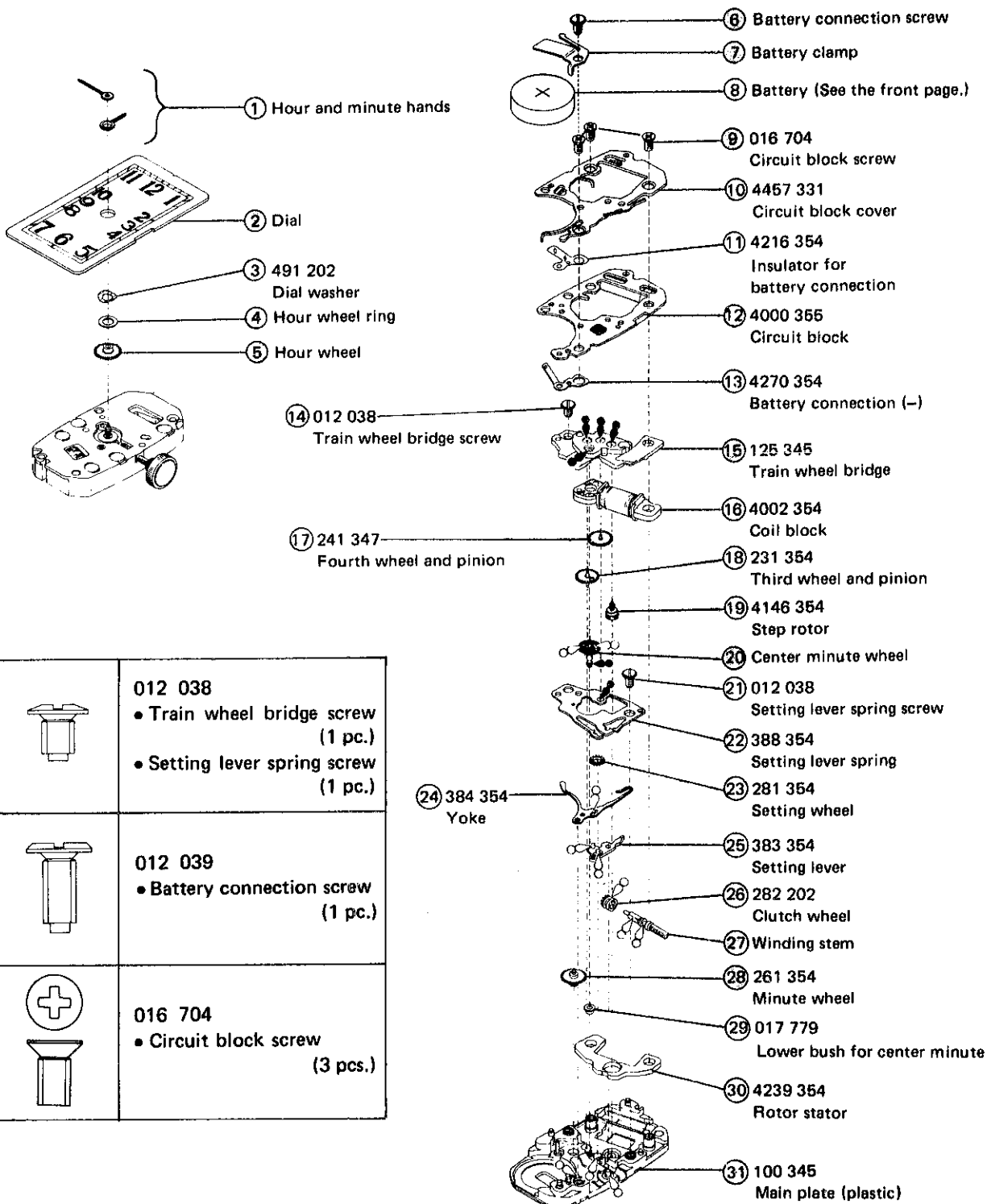

	<p>012 038</p> <ul style="list-style-type: none"> • Train wheel bridge screw (1 pc.) • Setting lever spring screw (1 pc.)
	<p>012 039</p> <ul style="list-style-type: none"> • Battery connection screw (1 pc.)
 	<p>016 704</p> <ul style="list-style-type: none"> • Circuit block screw (3 pcs.)

○ ← Please see the remarks on the following pages.



④ Hour wheel ring

- 493 201 Height 0.03 mm
- 493 202 Height 0.05 mm
- 493 203 Height 0.07 mm

⑤ Hour wheel

⑳ Center minute wheel

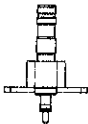
Combination:

	M
Center Minute Wheel	 270 202
Hour Wheel	 271 202

⑥ Battery connection screw 012 039

⑦ Battery clamp 4225 210

Some models are not provided with the battery clamp screw and battery clamp, depending on the design of case.

㉑ Winding stem 351 205 / 351 206

The type of winding stem is determined based on the design of case.
 Check the case number and refer to "SEIKO Casing Parts Catalogue" to choose corresponding winding stem.

- The explanation here is only for the particular points of Cal. 2E20B.
- For the repairing, checking and measuring procedures, refer to the "TECHNICAL GUIDE, GENERAL INSTRUCTIONS".

I. STRUCTURE OF THE CIRCUIT BLOCK

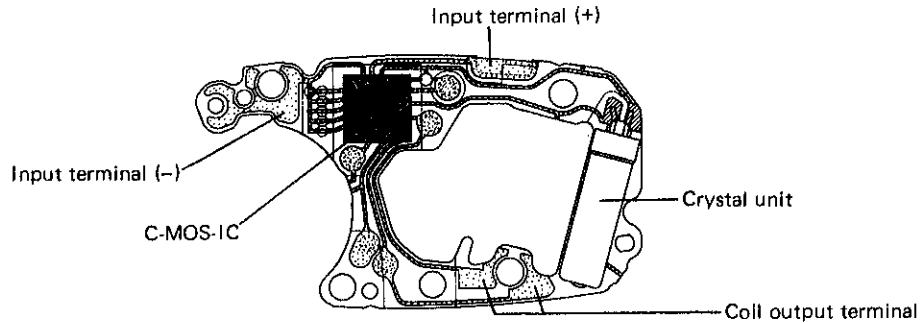

II. REMARKS ON DISASSEMBLING AND REASSEMBLING

① Hands

• How to install

Place the movement directly on a flat metal plate or the like to install the hands. In doing so, make sure that the spring portion of the circuit block cover is not pressed.

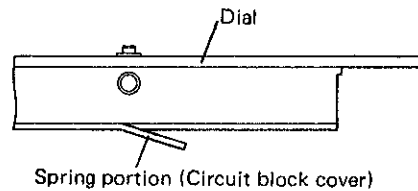

② Dial

⑤ Hour wheel

• How to install

Since a plastic minute wheel is used, securely engage the hour wheel with the pinion of the minute wheel, and then gently set the dial.

⑨ Circuit block screw

Since a cross recessed head screw is used, use S-921 screwdriver (Phillips type screwdriver for watch) to turn the circuit block screw.

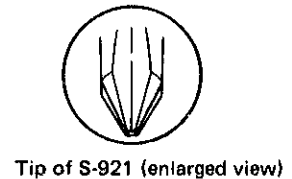
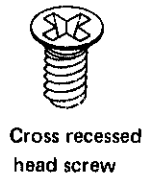

⑮ Train wheel bridge

• Setting position

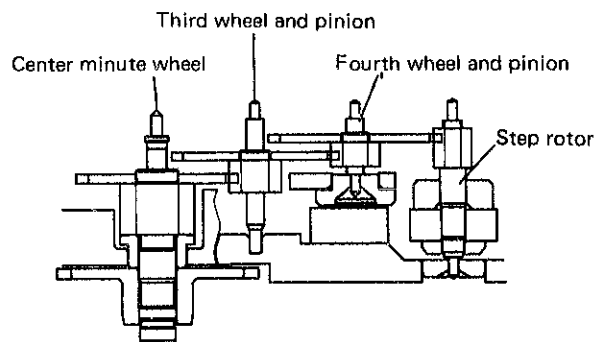
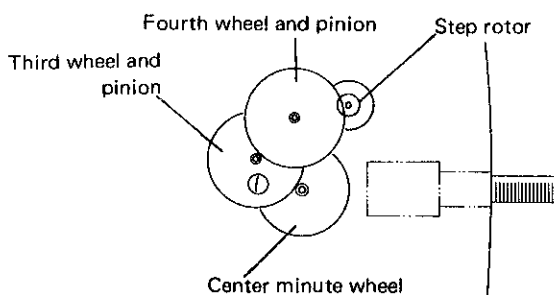

②7 Winding stem

- **How to install**

To prevent any crack onto the main plate, gently set the winding stem while turning it.

②8 Minute wheel

Since a plastic minute wheel is used, take care not to damage its wheel and pinion.

III. VALUE CHECKING

- **Coil block resistance:**

1.7K Ω ~ 2.1K Ω

- **Current consumption**

For the whole movement : Less than 0.6 μ A

For the circuit block only : Less than 0.3 μ A