

PARTS CATALOGUE/TECHNICAL GUIDE

Cal. H021B

Cal. H022A

Cal. H023A

[SPECIFICATIONS]

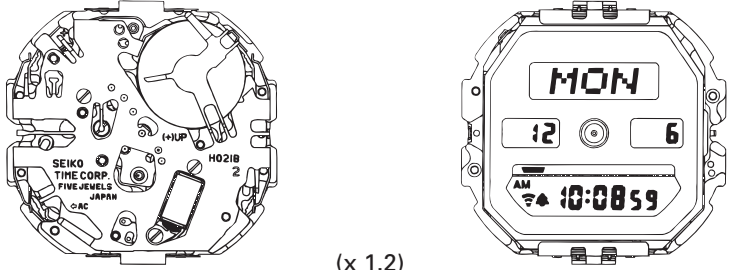
Item		Cal. No.	H021B , H022A , H023A
Movement			 <p>(x 1.2)</p>
Movement size	Outside diameter	ø31.0 mm 29.0 mm between 3 o'clock and 9 o'clock sides 28.5 mm between 12 o'clock and 6 o'clock sides	
	Casing diameter	ø30.0mm 29.0 mm between 3 o'clock and 9 o'clock sides 28.5 mm between 12 o'clock and 6 o'clock sides	
	Height	5.5 mm	
Time indication		Analogue section	Digital section
		3 hands (Hour, minute and second hands)	Nematic Liquid Crystal, FEM (Field Effect Mode)
Driving system		Step motor, 2 pieces	Multiplex driving system
Display system		<ul style="list-style-type: none"> • Time/calendar display (City display by the second hand) • World time display (City display by the second hand) 	<ul style="list-style-type: none"> • Time/calendar display • Month, date, day of the week and fully automatic calendar up to the year 2043 • Hour, minute and second • Automatic daylight saving time function • World time display • 28 cities on display • Automatic daylight saving time function • Display of time difference between the selected city and your area • Stopwatch display • Up to 100 hours (Hour, minutes, seconds and 1/1000 seconds) • Alarm display • Daily alarm (H021B,H022A: 2 channels, H023A: 1 channel)
Additional mechanism		—	<ul style="list-style-type: none"> • Hourly time signal • Alarm test system • Sound for button operation confirmation • Battery life indicator
Loss/gain		Monthly rate within normal temperature range: less than 15 seconds	
Regulation system		Nil	
Measuring gate by quartz tester		Use 10-second gate.	
Battery		SB-BU (SR1130W) Battery life is approximately 2 years. Voltage: 1.55V	
Jewels		5 jewels	





SEIKO WATCH CORPORATION

PARTS CATALOGUE

Cal. H021B, H022A, H023A

Disassembling procedures Figs. : ① → ④②
 Reassembling procedures Figs. : ④② → ①

Lubricating : Types of oil Oil quantity

	Moebius A		Normal quantity
	Moebius F		
	Silicone Oil 500,000 c.s.		

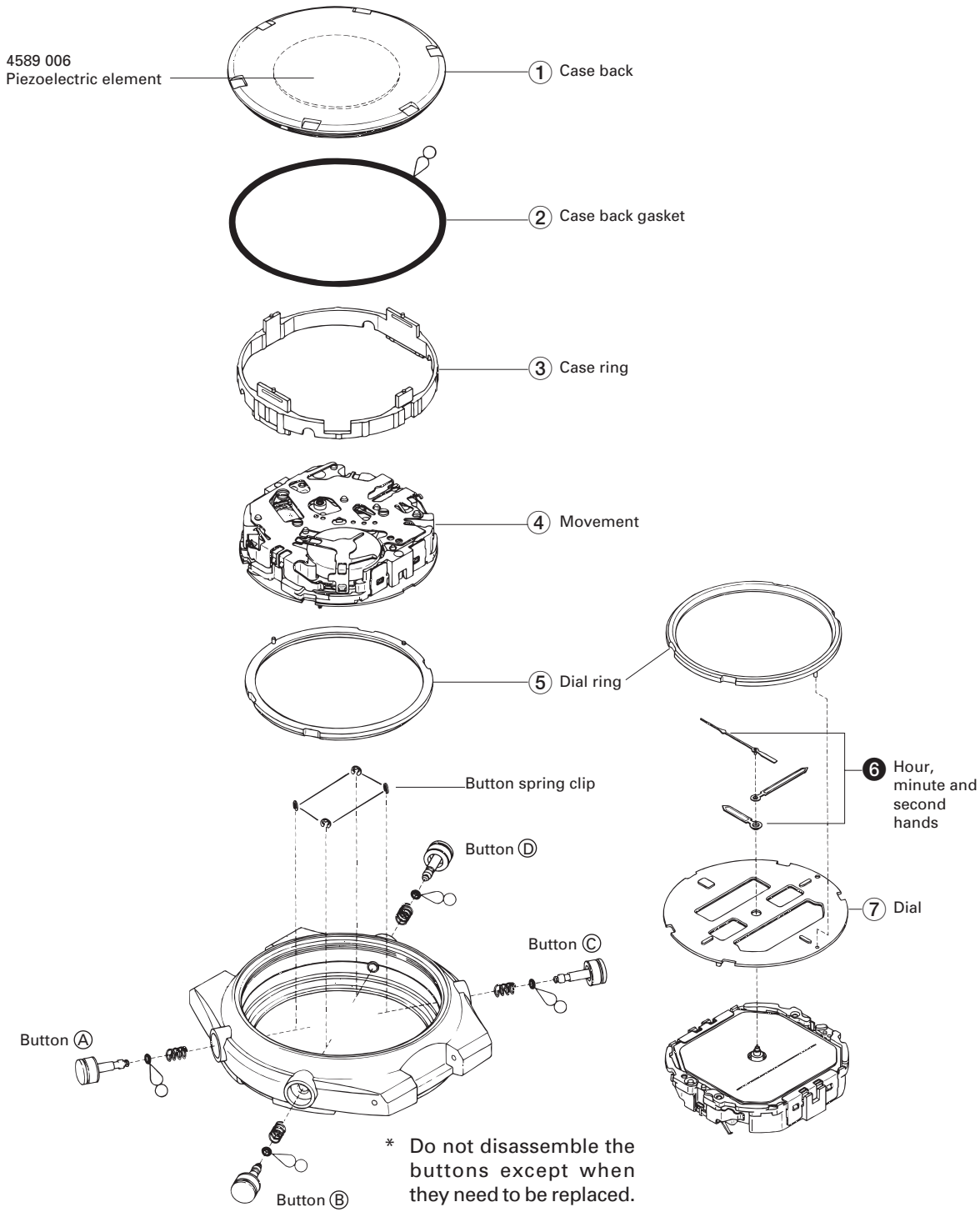



● For the part ⑥, please see the remarks on the following pages.

PARTS CATALOGUE

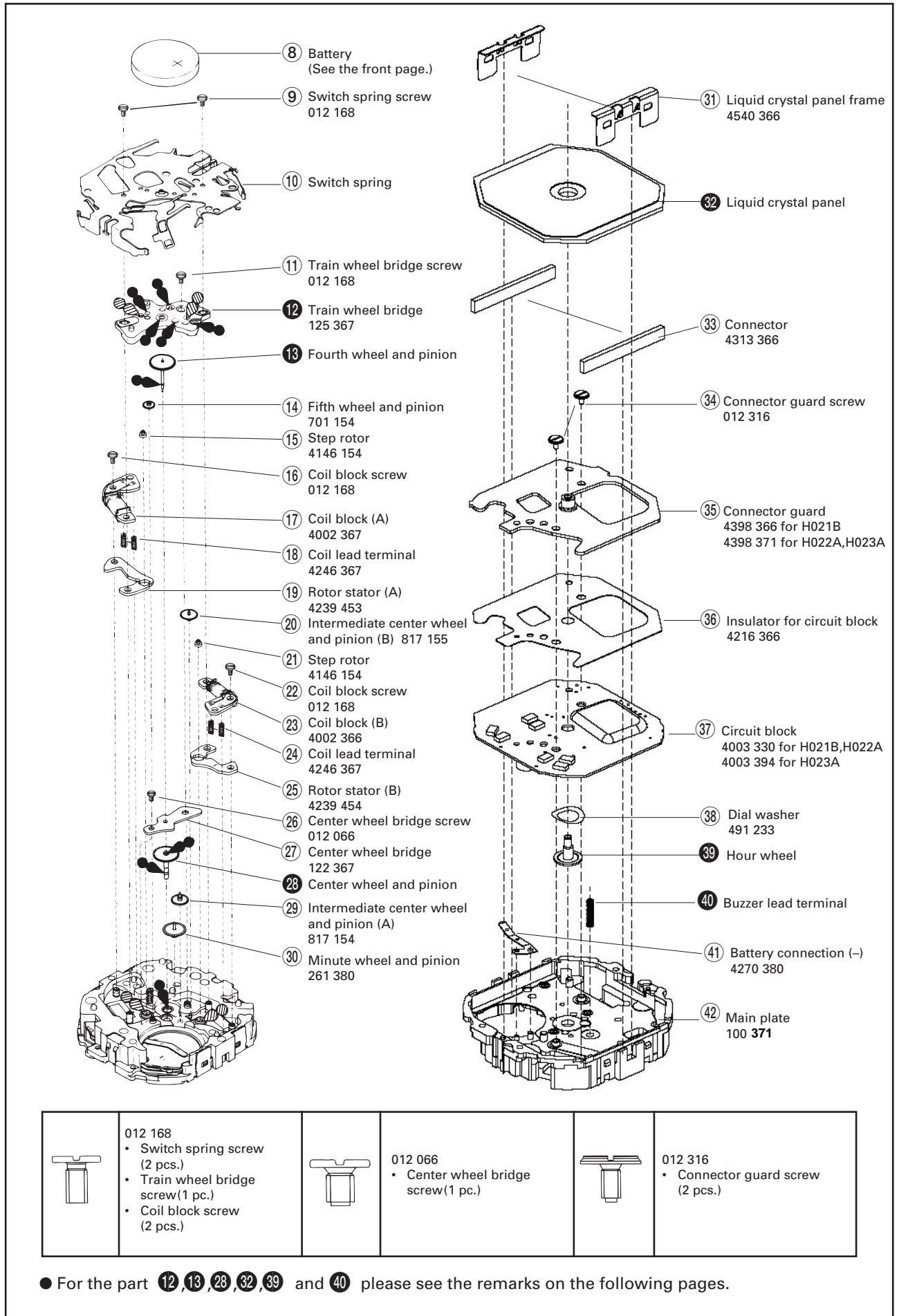
Cal. H021B, H022A, H023A



 <p>012 168</p> <ul style="list-style-type: none"> • Switch spring screw (2 pcs.) • Train wheel bridge screw (1 pc.) • Coil block screw (2 pcs.) 	 <p>012 066</p> <ul style="list-style-type: none"> • Center wheel bridge screw (1 pc.) 	 <p>012 316</p> <ul style="list-style-type: none"> • Connector guard screw (2 pcs.)
--	--	---

● For the part 12, 13, 28, 32, 39 and 40 please see the remarks on the following pages.

PARTS CATALOGUE

Cal. H021B, H022A, H023A

Remarks

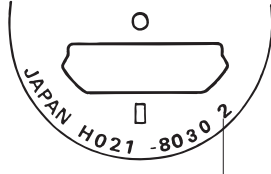
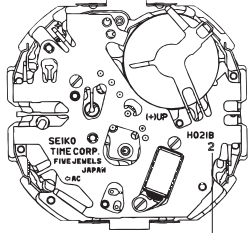

• Discrimination of the hand installation height

Refer to the table below to find the numerals to indicate the hand installation height which is printed on the dial and movement.

Discrimination	Height	Standard type	Standard type
	Numeral for discrimination	2	2
Printed on		Dial	Movement
Printed position		 <p>The numeral is printed at the right end.</p>	 <p>The numeral is printed below the calibre number.</p>

⑬ Fourth wheel and pinion ⑳ Center wheel and pinion ㉔ Hour wheel

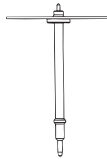
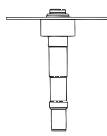
These parts are determined by the hand installation height. Refer to the table below to choose the appropriate part for each caliber.

Numeral for discrimination	Fourth wheel and pinion	Center wheel and pinion	Hour wheel
2			
(H021B)	221 379	241 362	271 380
(H022A,H023A)	221 053	241 275	271 489

• In a case where the numeral for discrimination is not printed on the movement (switch spring), see the numeral printed on the dial or refer to the table above to identify each part by its shape.

⑩ Switch spring

Cal.H021B: 4245 330

Cal.H022A: 4245 375

Cal.H023A: 4245 131

⑳ Liquid crystal panel

The type of liquid crystal panel differs depending on the model. Refer to "SEIKO Watch Parts Catalogue (CD-ROM)" to choose the appropriate type of the crystal panel.

㉔ Buzzer lead terminal

Cal.H021B: 4246 336

Cal.H022A, H023A: 4246 368

● Piezoelectric element

Piezoelectric element, which is adhered to the case back, is provided independently.

- The explanation here is only for the particular points of Cal. H021B, H022A and H023A.
- For the repairing, checking and measuring procedures, refer to the "TECHNICAL GUIDE, GENERAL INSTRUCTIONS".

I. STRUCTURE OF THE CIRCUIT BLOCK

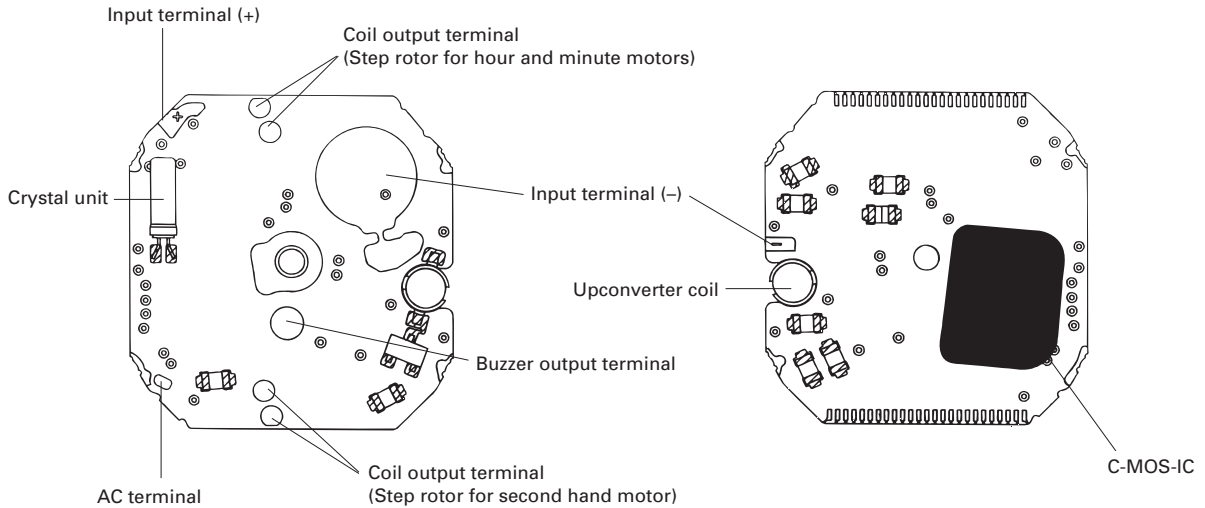

II. REMARKS ON INSTALLING THE BATTERY

1. After the battery is replaced with a new one, or after the battery is re-installed following the repairing procedures, be sure to short-circuit the AC terminal of the circuit block and the switch spring with conductive tweezers to reset the circuit as illustrated at right.

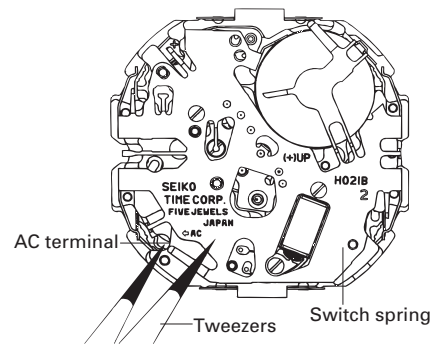

2. To reset the circuit of the watch with its case back closed, press the buttons "A", "B", "C" and "D" at the same time and hold them for 2 to 3 seconds until the display becomes blank. Then release the buttons and check that the display shows "12:00'00" AM, Saturday, January 1st" .

* Before closing the case back, apply a small quantity of silicon oil to the contact portion of the case back with the buzzer lead terminal (piezoelectric element).

3. Be sure to set the digital time first before setting the analogue time, as the analogue hands are governed by the digital time.

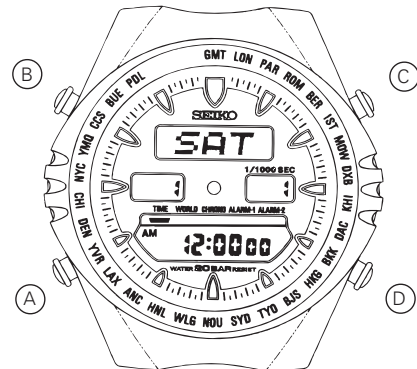

* For time/calendar setting, refer to the instruction booklet of each caliber.

III. REMARKS ON DISASSEMBLING AND REASSEMBLING

Use the universal movement holder for disassembling and reassembling.

⑥ Hands

• Remarks on installing

After installing the battery in the movement, place the movement on a flat metal plate or the like to install the hands.

- * Install the hour and minute hands at the 12 o'clock position within 60 seconds after resetting the circuit.
- * When installing the second hand, be sure to check that it accurately points to a second marker on the dial. This is because in some modes it indicates city names which may be located between second markers. If not installed correctly, the second hand will not properly indicate the city names.

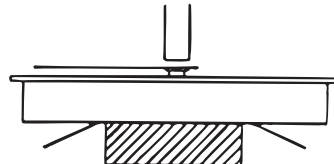

⑧ Battery

⑩ Switch spring

• How to install

1. Set the switch spring in position, taking care not to damage the two guide pins for the main plate. Then, tighten the two switch spring screws.
2. Make sure the two hooks of the switch spring engage the main plate.
3. Insert the battery sideways, and have the hook of the switch spring's battery clamp portion catch the main plate.

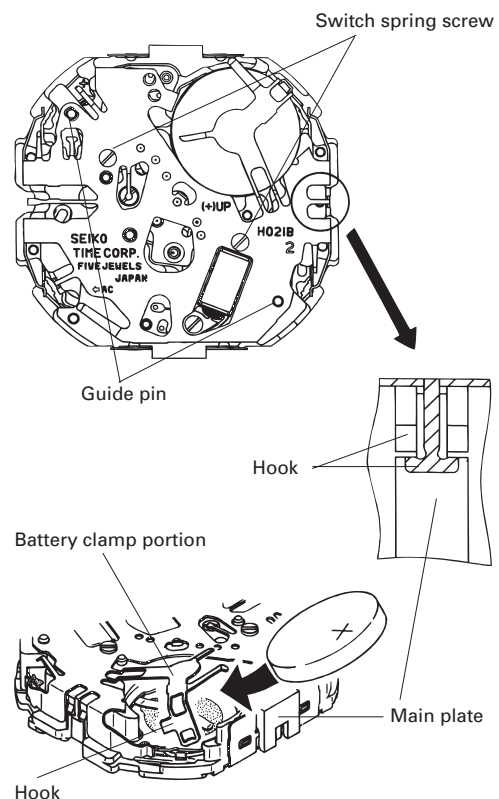

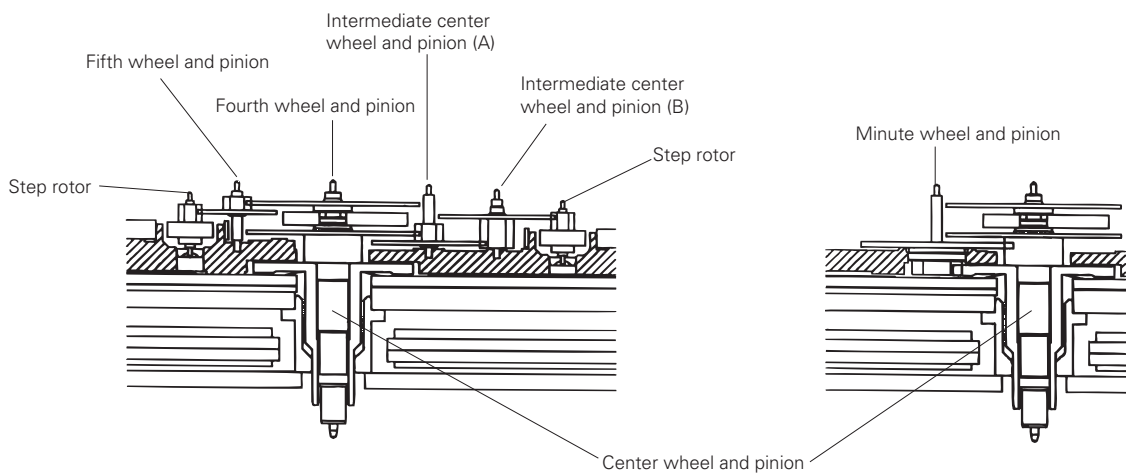
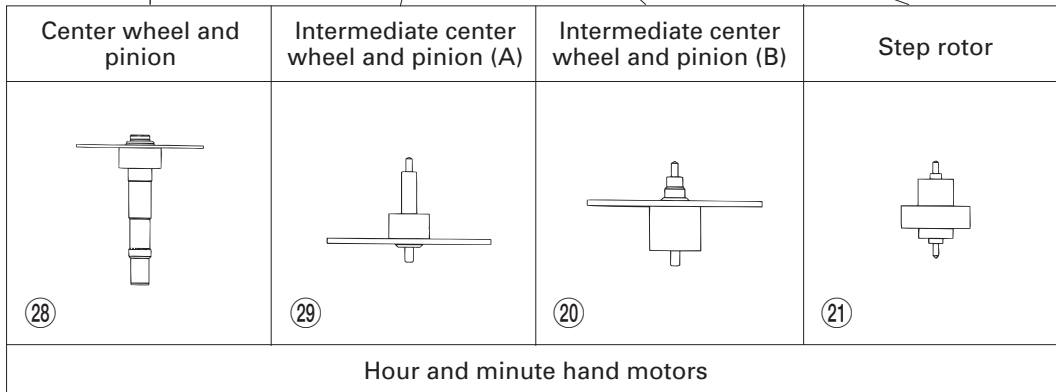
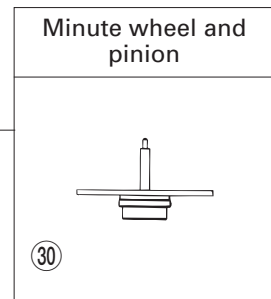
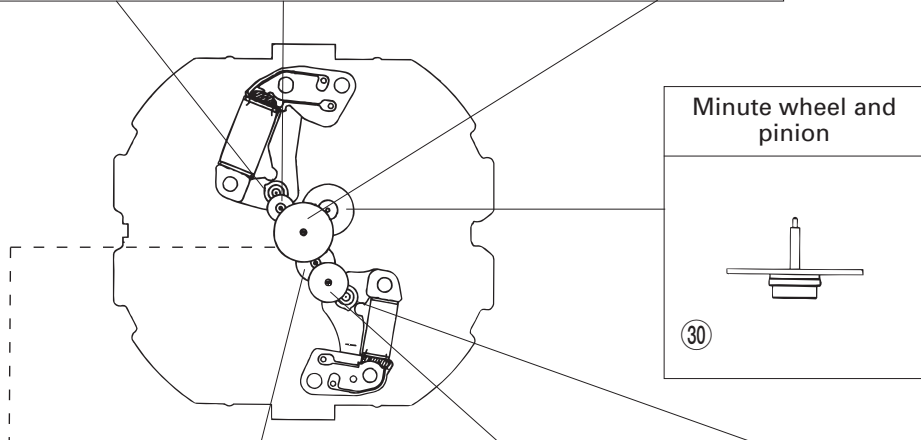
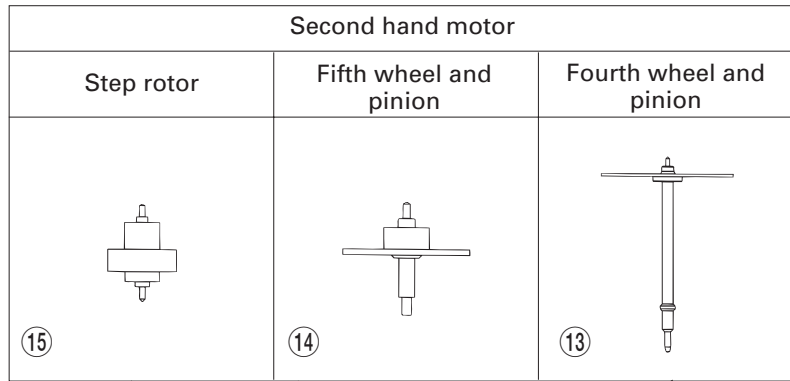

⑫ Train wheel bridge

• Setting position

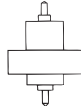
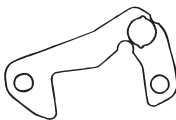

• Distinction of motors

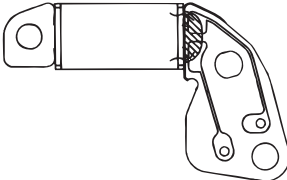
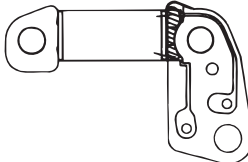
Part name \ Distinction	Second hand motor	Hour and minute hand motors
Step rotor	 4146 154	
Rotor stator	 4239 453 No discrimination number	 4239 454 Discrimination number "1"
Coil block	 4002 367	 4002 366

- * The step rotors can be used interchangeably.
- * The rotor stator can be identified by the discrimination number printed on it.
- * For the identification of the coil blocks, see the table above to check the difference of their shapes.

IV. VALUE CHECKING

- **Time accuracy**

To measure the accuracy, light up all the segments. To do so, press buttons "C" and "D" at the same time in the TIME/CALENDAR SETTING display.

After the measurement, press any one of the button "A", "B", "C" or "D" to return to the TIME/CALENDAR display.

- **Upconverter coil resistance**

135Ω ~ 165Ω

- **Coil block resistance**

Coil block (A): 1.5KΩ ~ 2.1KΩ

Coil block (B): 1.1KΩ ~ 1.7KΩ

- **Current consumption**

For the whole movement : less than 4.7μA

For the circuit block alone : less than 1.5μA

Notes:

- Before measuring the current consumption, be sure to reset the circuit. Otherwise, current consumption cannot be measured properly.
- When the current consumption exceeds the standard value for the whole movement but is within the standard value range for the circuit block alone, the watch is generating the driving pulse for compensating for the heavy load that may be applied to the gear train, etc.
In this case, overhaul and clean the movement parts and then measure current consumption for the whole movement again.