

TECHNICAL GUIDE AND PARTS LIST

CAL. Y960

COMBINATION QUARTZ

CONTENTS

I. FOREWORD	1
1. System reset.....	1
2. Notes on circuit block installation	1
II. SPECIFICATIONS	2
III. SCREWS USED.....	2
IV. OPERATION	3
V. DISASSEMBLING, REASSEMBLING AND LUBRICATING	4
1. Case ~ Movement.....	4
2. Rear side of the movement (Liquid crystal panel holder screw ~ Coil lead terminal).....	5
3. Front side of the movement (Battery clamp screw - Winding stem).....	6
VI. CHECKING AND ADJUSTMENT	7
1. Structure of circuit block.....	7
2. Relationship between the segments (Liquid crystal panel electrodes) and C-MOS-LSI output terminals	7
3. Procedures for checking and adjustment.....	8
VII. PARTS LIST.....	11

FOREWORD

1. System reset

The Cal. Y960A requires the system reset procedure, because the incorrect display shows on the liquid crystal panel, when the battery is replaced. At that time, perform the system reset as follows.

< System reset procedure >

Contact the battery and system reset pattern with conductive tweezers as shown below. (A label which gives the procedure is attached to the battery clamp.)

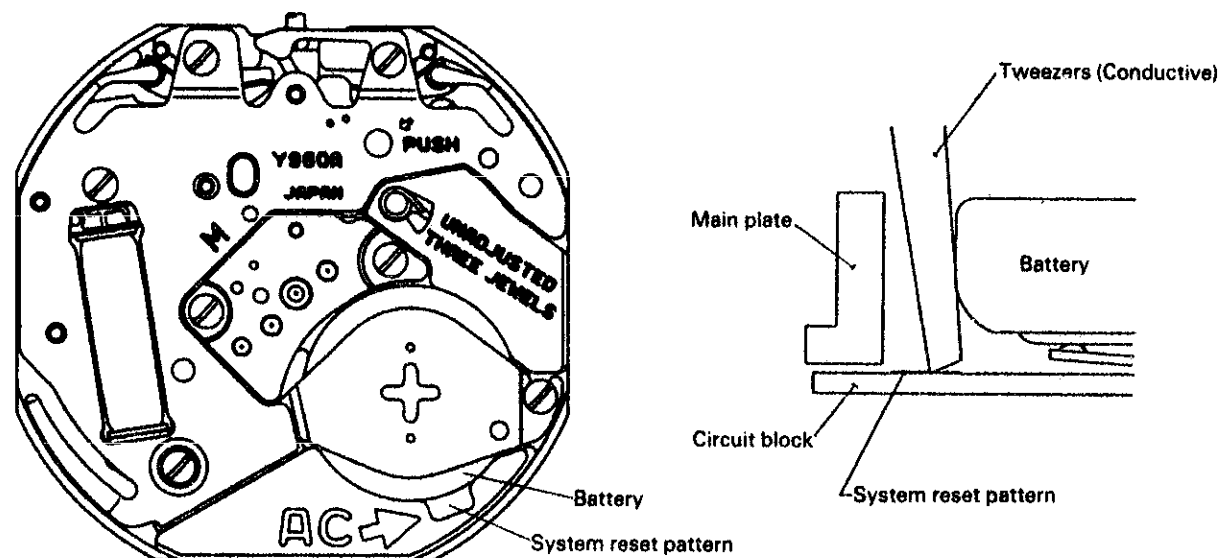

2. Notes on circuit block installation

Three switch pins are soldered to the circuit block to make the contact with the switch lever and yoke. When the circuit block is reassembled, proceed as follows.

- (1) Set the crown at the normal (fully inserted) or second click (fully pulled) position.
- (2) Rotate the crown so that the winding stem cam does not make contact with switch lever (Figure below).

Viewed from the 3 o'clock position

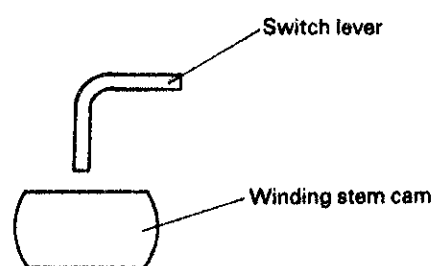

II. SPECIFICATIONS

Item	Cal. No.	Y960A	
		Analogue section	Digital section
Display medium		Three hands	Nematic Liquid Crystal, FEM (Field Effect Mode)
Drive system		Step motor	Multiplex driving
Display system			Time function Calendar function Alarm time function
Additional mechanism		Second setting device Electric circuit reset switch	Alarm test
Loss/gain		Monthly rate: less than 20 seconds at normal temperature range	
Movement size	Maximum diameter	ø26.4 mm (3H - 9H 23.5 mm, 12H - 6H 24.2 mm)	
	Casing diameter	ø25.6 mm (3H - 9H 23.5 mm, 12H - 6H 24.2 mm)	
	Height (including battery)	3.55 mm	
Regulation system		None	
Measuring gate		Any gate is available	
Battery		SEIKO TR920W or MAXELL SR920W Voltage: 1.55V Battery life: Approx. 2 years	
Jewels		3 jewels	

III. SCREWS USED

In Cal Y960A, two types of screws are used. The head diameter differs from each other as shown in the table below. Note the difference for disassembly and reassembly.

Parts code	Appearance	Description and number	Difference
022 247		Setting lever spring screw 1 pce. Train wheel bridge screw 2 pcs. Coil block cover screw 4 pcs. Circuit block screw 1 pce. Anti-magnetic shield plate screw 2 pcs. Battery clamp screw 1 pce.	Large head
022 248		Liquid crystal panel holder screw 4 pcs.	Small head

IV. OPERATION

1. When the crown is turned at the normal position, the mode changes as follows.

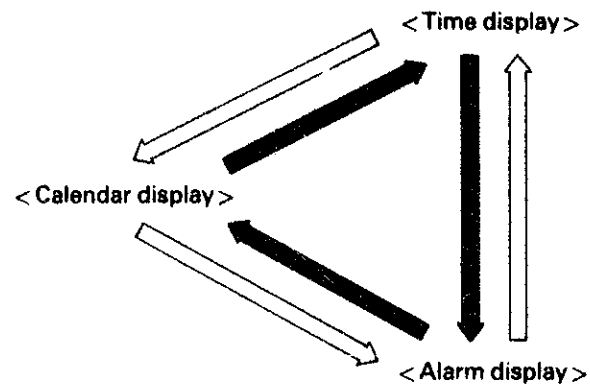

2. Crown at the first click position

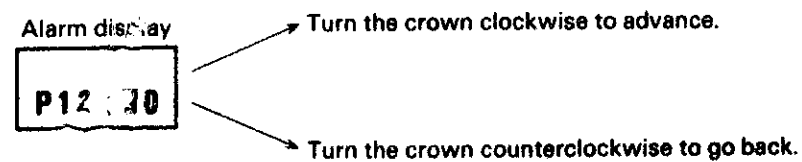
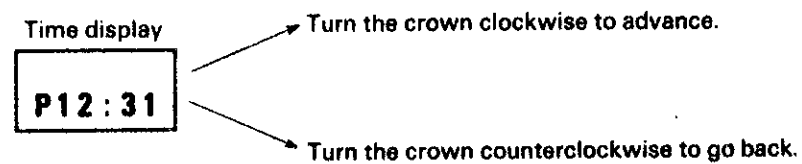
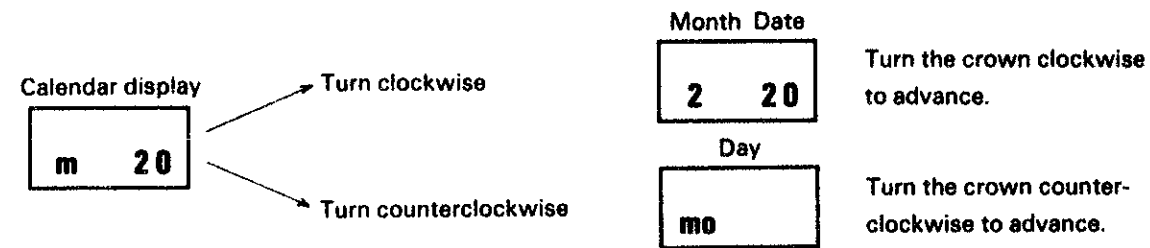

* When the crown is pushed to the normal position in the alarm display, the alarm sounds. The alarm can be turned ON/OFF by inserting the crown immediately after it is pulled. When the alarm time is set, the alarm is set to ON.

3. How to set the analogue time

In the time display, pull out the crown to the second click when the second hand is at 12 o'clock position, and the digital seconds are reset to "00" though not displayed.

Turn the crown clockwise to advance the hands, and counterclockwise to turn them back. Push the crown to the normal position in accordance with a time signal.

All segments are simultaneously displayed, when the crown is turned clockwise or counterclockwise at normal position in the time display and the crown is pulled to the first click position.

V. DISASSEMBLING, REASSEMBLING AND LUBRICATING

1. Case ~ Movement

Lubricating: ● Moebius A

Disassembling procedures: Figs ① ~ ⑤

Reassembling procedures: Figs ⑥ ~ ①

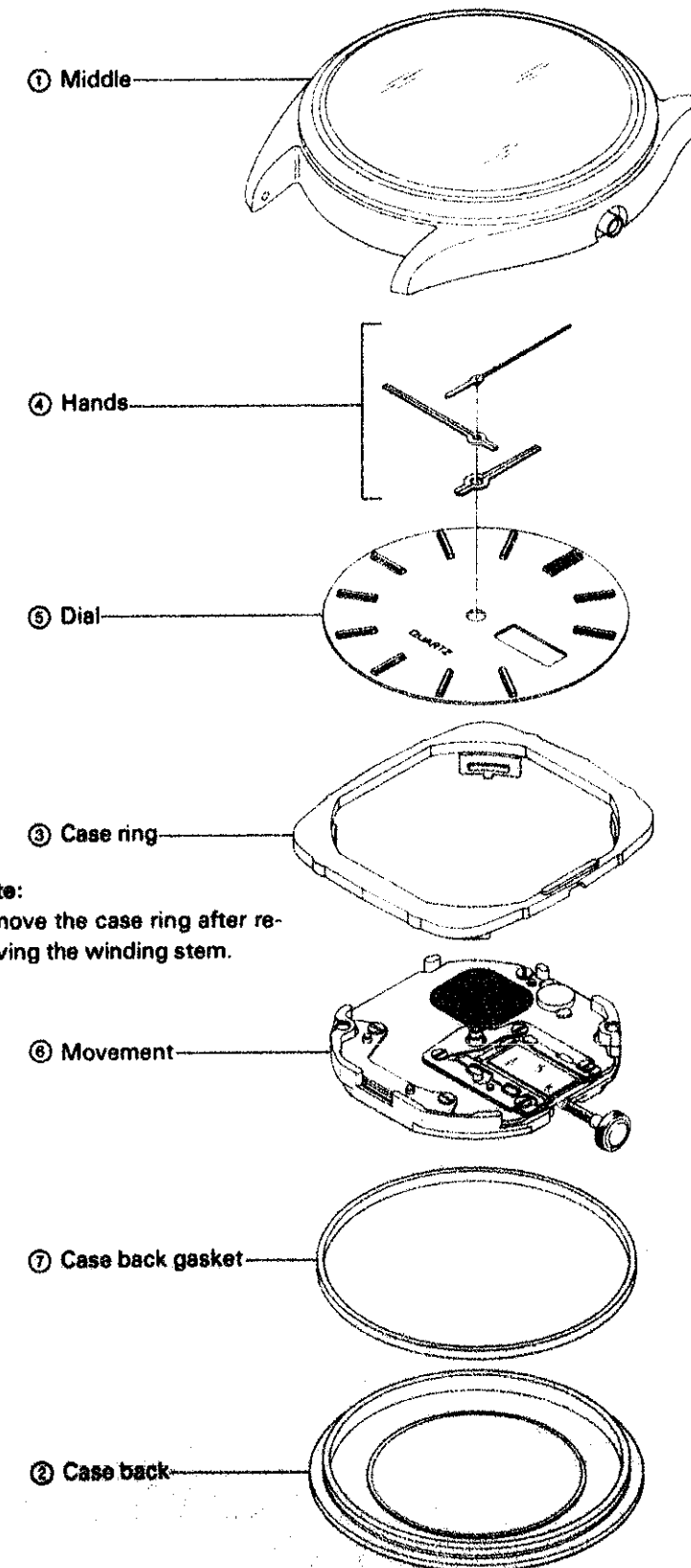

Note:

How to remove the winding stem

Set the crown to the second click position and press the setting lever viewed from the hole shown below to remove the winding stem.

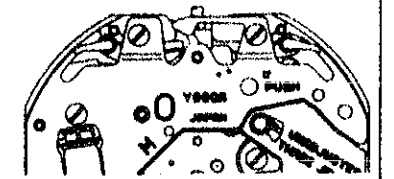

Note:

Remove the case ring after removing the winding stem.

**2. Rear side of the movement
(Liquid crystal panel holder screw ~ Coil lead terminal)**

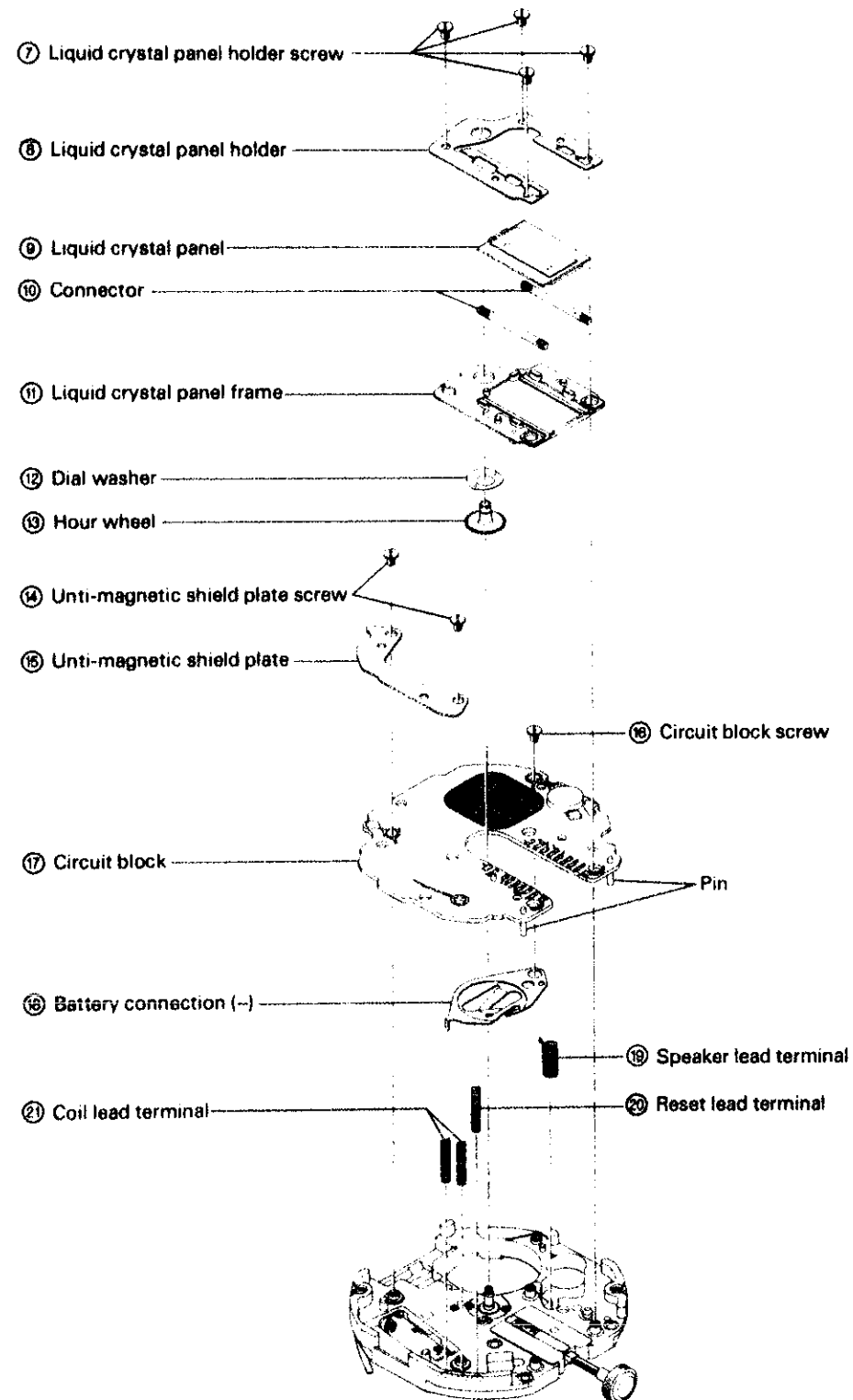

Note:
As the connectors are symmetrical, they can be mounted either position.

Notes on handling the circuit block:
As 3 pins are soldered to the circuit block, take care not to bend or break them.

Note:
The reset lead terminal and coil lead terminal are the common parts and differ from the speaker lead terminal.

**3. Front side of the movement
(Battery clamp screw - winding stem)**

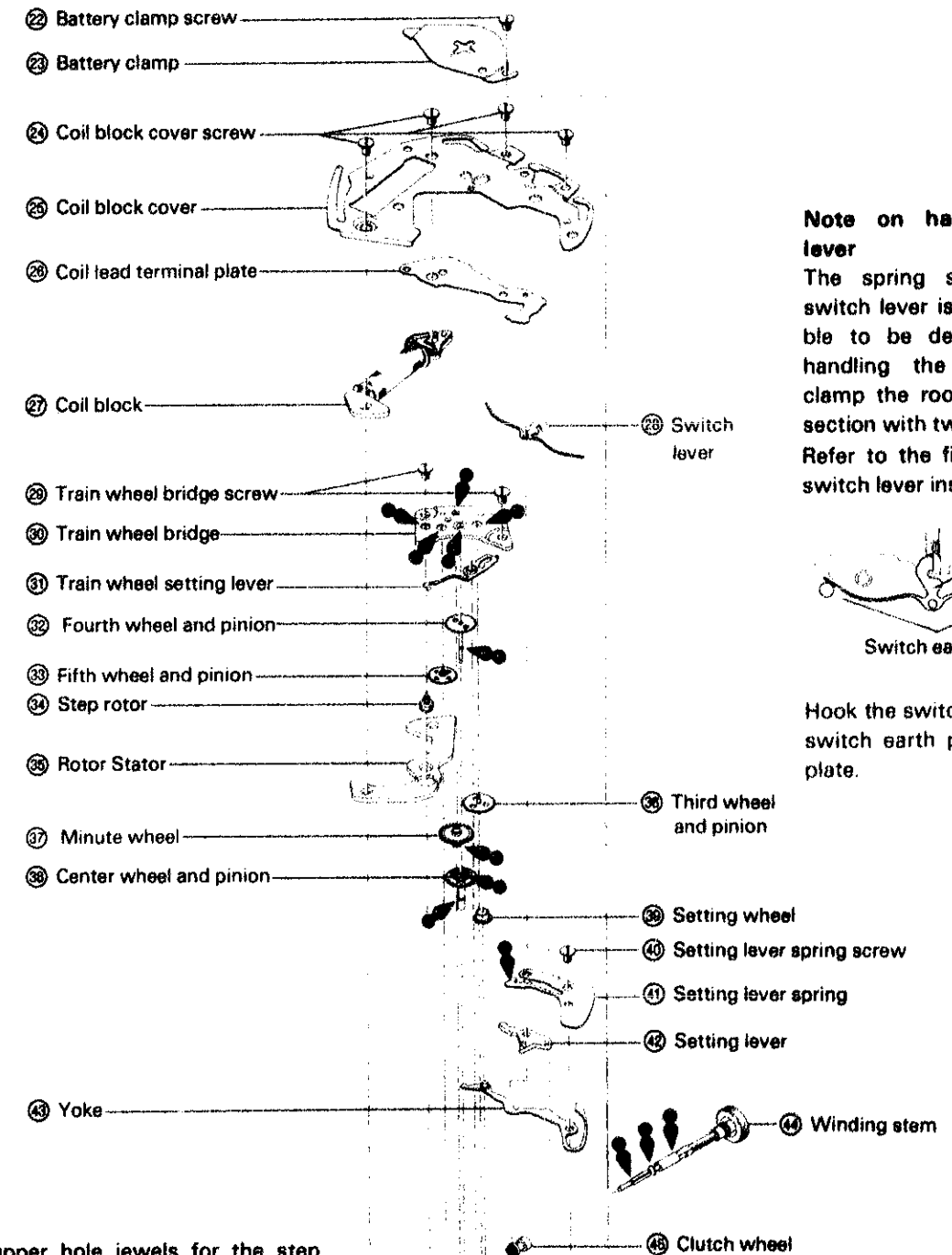

Note on handling switch lever

The spring section of the switch lever is thin and is liable to be deformed. When handling the switch lever, clamp the root of the spring section with tweezers. Refer to the figure below for switch lever installation.

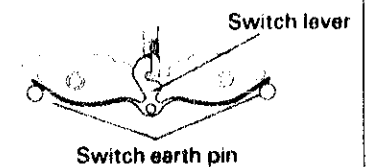

Hook the switch lever with the switch earth pin of the main plate.

Note:

The upper hole jewels for the step rotor, third wheel & pinion and fifth wheel & pinion are reversely installed in order to properly set the wheels and pinions with ease.

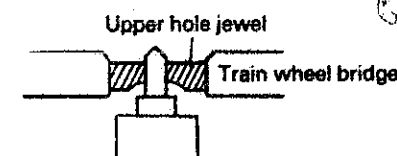

**2. Rear side of the movement
(Liquid crystal panel holder screw ~ Coil lead terminal)**

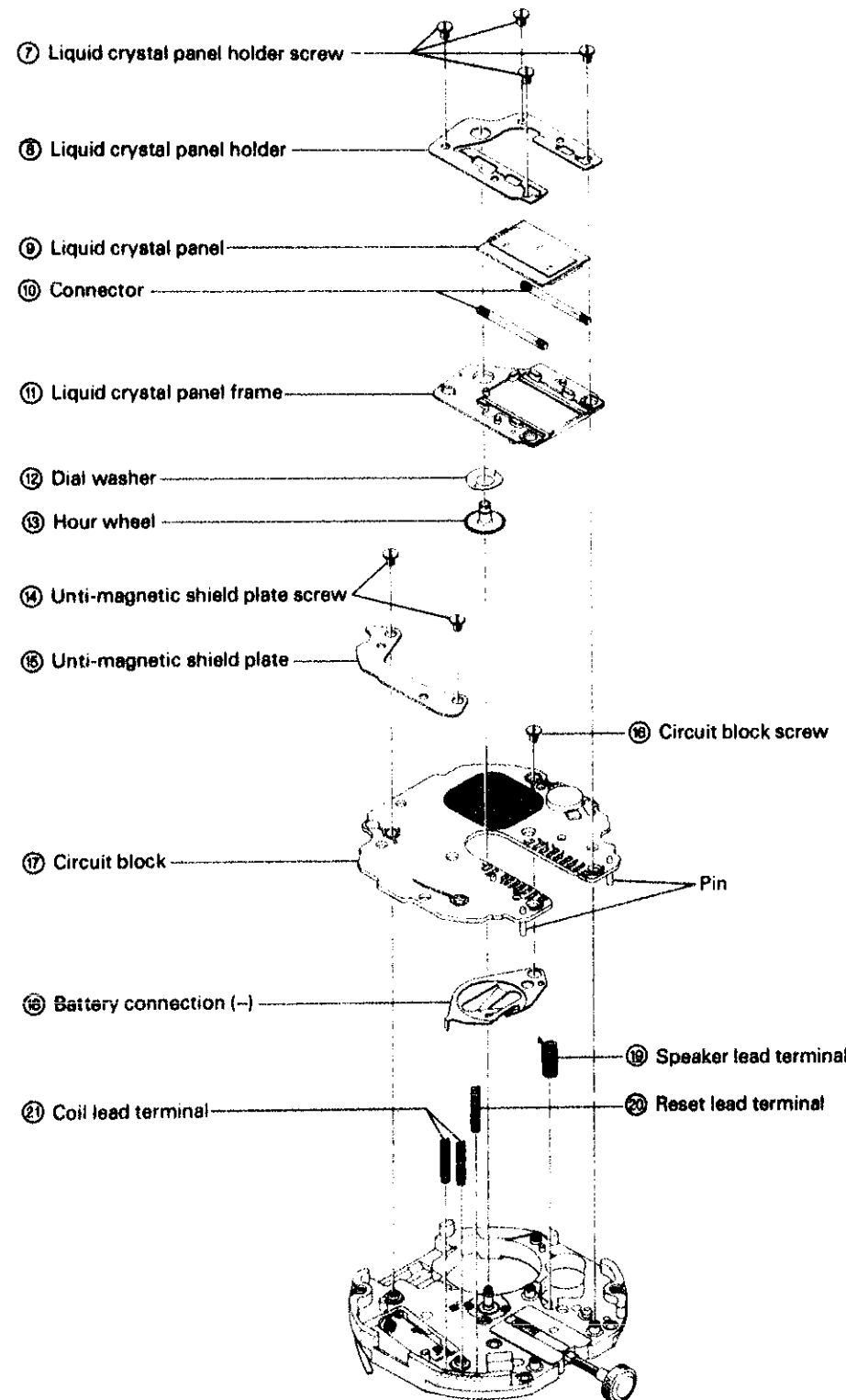

Note:
As the connectors are symmetrical, they can be mounted either position.

Notes on handling the circuit block:
As 3 pins are soldered to the circuit block, take care not to bend or break them.

Note:
The reset lead terminal and coil lead terminal are the common parts and differ from the speaker lead terminal.

**3. Front side of the movement
(Battery clamp screw - winding stem)**

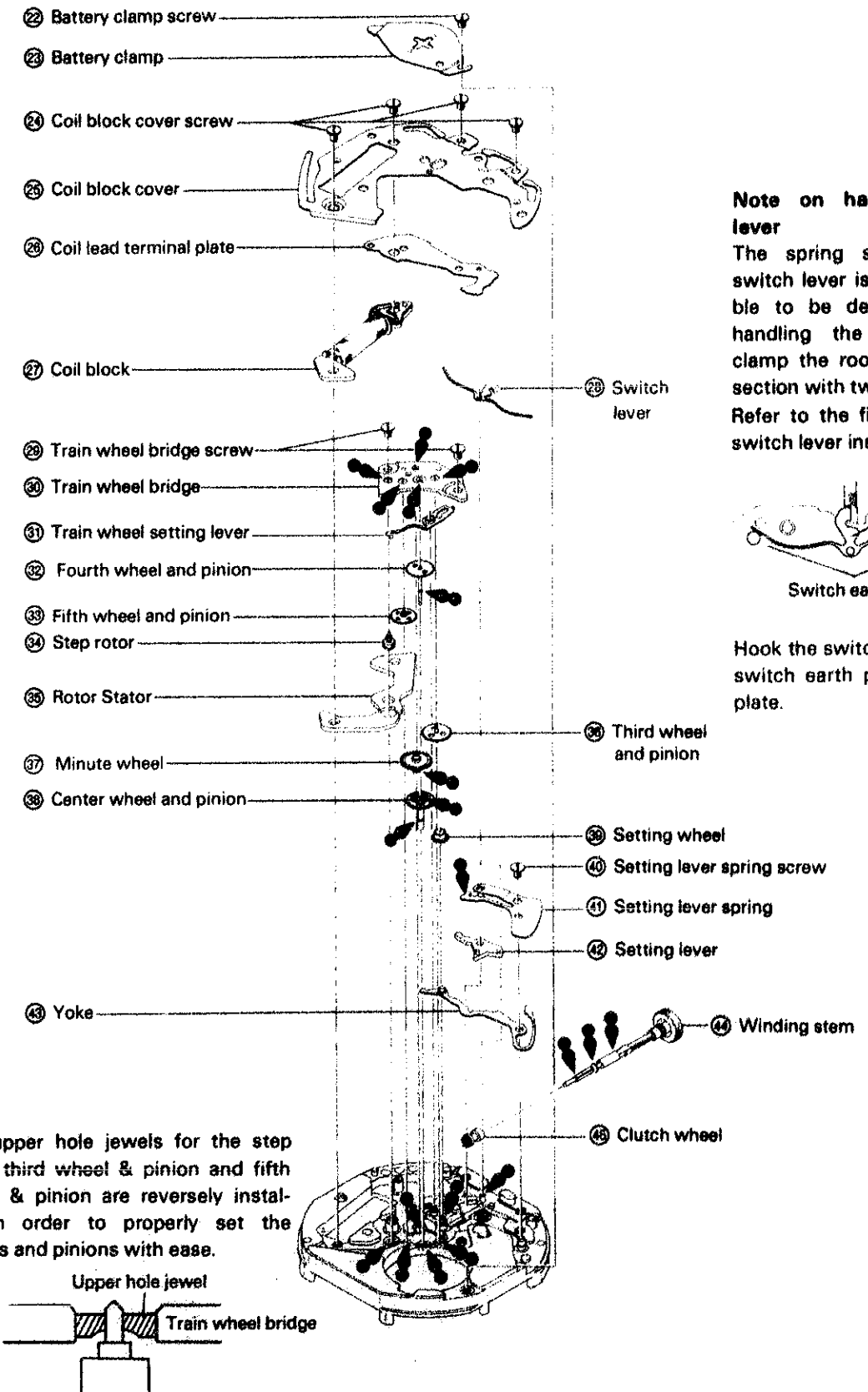

Note on handling switch lever

The spring section of the switch lever is thin and is liable to be deformed. When handling the switch lever, clamp the root of the spring section with tweezers. Refer to the figure below for switch lever installation.

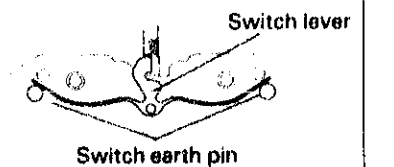

Hook the switch lever with the switch earth pin of the main plate.

Note:
The upper hole jewels for the step rotor, third wheel & pinion and fifth wheel & pinion are reversely installed in order to properly set the wheels and pinions with ease.

VI. CHECKING AND ADJUSTMENT

1. Structure of circuit block

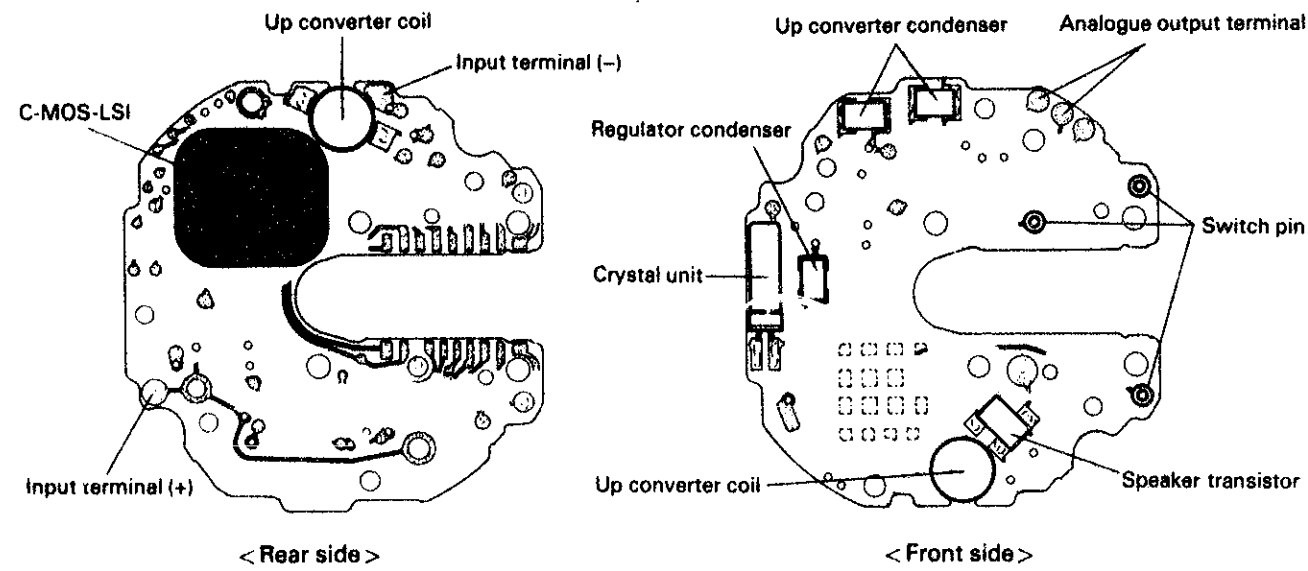

2. Relationship between the segments (Liquid Crystal panel electrodes) and C-MOS-LSI output terminals

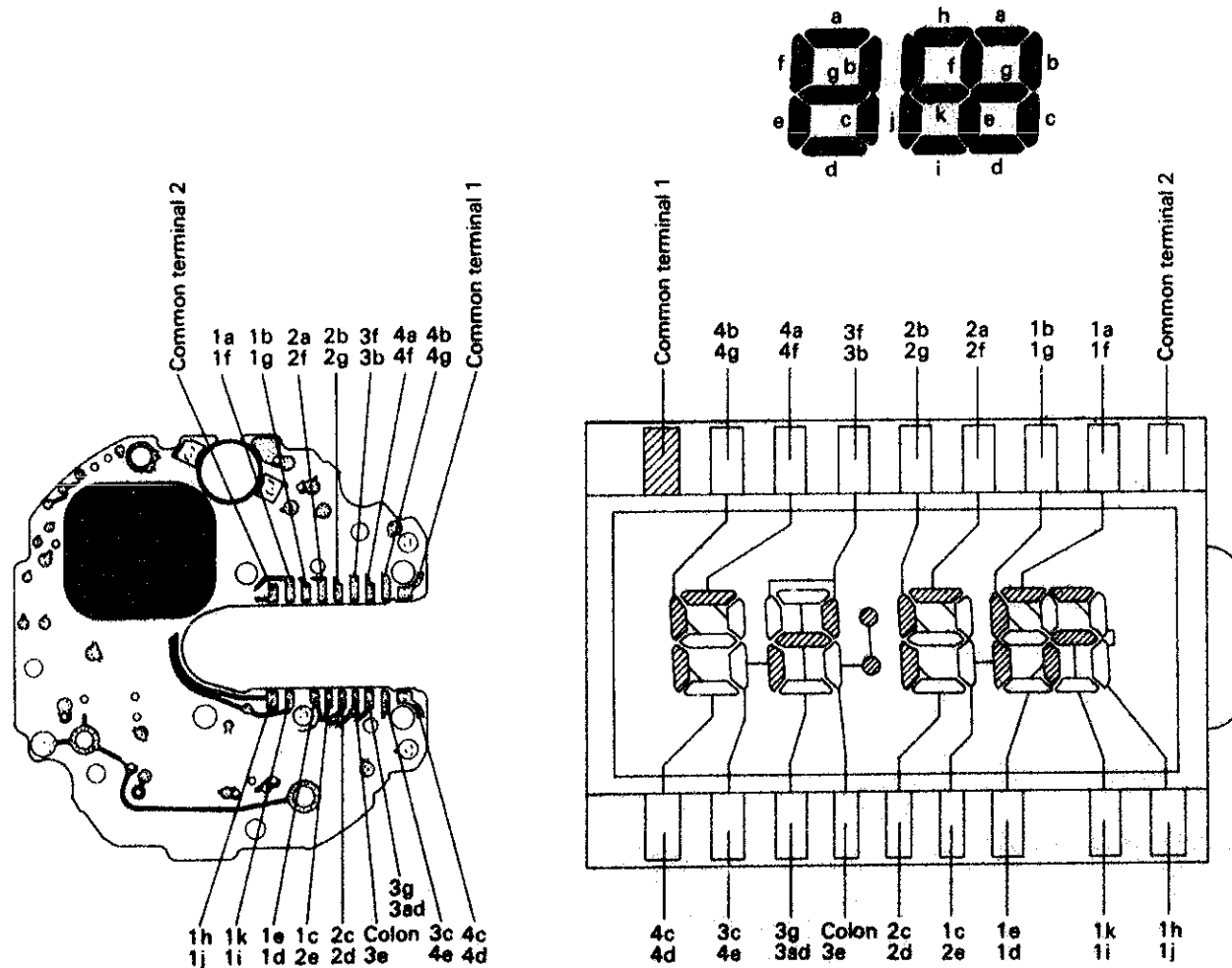

3. Procedures for checking and adjustment

- This section only gives the checking and adjustment procedures exclusive for Y960A.
- For details, refer to "TECHNICAL GUIDE GENERAL INSTRUCTION".

Procedures	Result and repair
<p>OUTPUT SIGNAL</p> <p>Check the output signal of every 1 second with the crown at normal position.</p>	<p>Output signal Normal</p> <p>No output signal Battery voltage check</p> <p>→ Battery voltage is normal Check coil block</p>
<p>BATTERY VOLTAGE</p> <p>Use the Digital Multi Tester S-840A.</p> <p>Range to be used: DC V</p>	<p>1.5V or more Normal</p> <p>Less than 1.5V Replace the battery.</p>
<p>BATTERY CONDUCTIVITY</p> <p>Check the conductivity between the battery and battery connection (-).</p>	
<p>CIRCUIT BLOCK CONDUCTIVITY</p> <p>Check the circuit block output terminal and pattern for contermination, break and short circuit.</p>	
<p>GEAR TRAIN MECHANISM</p> <p>Check the train wheel bridge for play of rotor and wheels and pinions, dust, lint, and lubrication.</p>	
<p>RESET CONDITION</p> <p>Reassemble the movement and check the reset condition with a quartz tester.</p> <p>(1) Check the output signal with the crown at normal position.</p> <p>(2) Check the output signal with the crown at second click position.</p>	<p>Output signal Normal</p> <p>No output signal Defective</p> <p>Proceed to (2)</p> <p>No output signal Normal</p> <p>Output signal Defective</p> <p>Replace the coil lead terminal plate.</p>

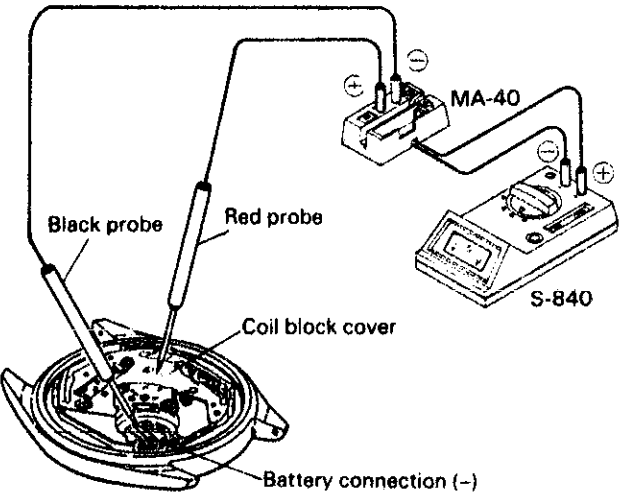
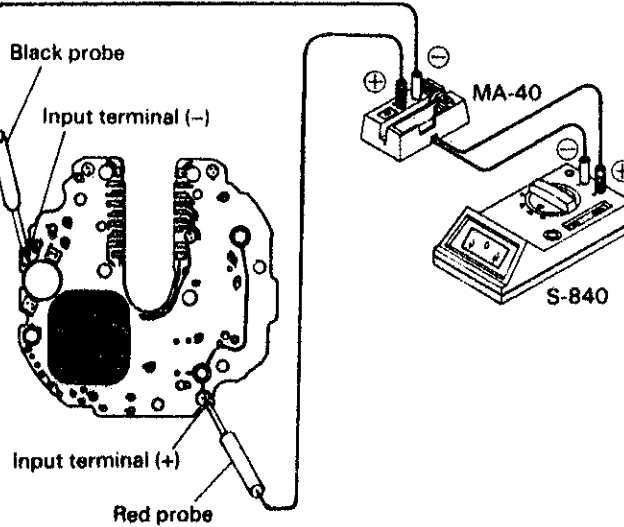
Procedures	Result and repair
<p>CURRENT CONSUMPTION</p> <p>(1) Check the current consumption of the module. ● Use the Digital Multi Tester S-840 and Multi Adaptor MA-40.</p>  <p>(2) Check the current consumption of the circuit block. ● Check in the same manner as in (1).</p> 	<p>2.3μA or less Normal More than 2.3μA Defective Check the current consumption of the circuit block.</p>
<p>ACCURACY</p> <ul style="list-style-type: none"> ● Check with quartz tester and electromagnetic microphone. <p>< Measuring ></p> <ul style="list-style-type: none"> ● Check with the crown at normal position. ● Set the digital section to the day or time display mode. <p>NOTE: The accuracy can be checked with the digital section. However, the display is small and it is difficult to check the movement. Check the accuracy with the analogue section.</p>	<p>1.1μA or less Normal If the coil block is not short circuited, replace the liquid crystal panel. More than 1.1μA Defective</p> <p>Monthly rate Less than 20 seconds Normal More than 20 seconds Defective</p>

Procedures	Result and repair
<p>CONDUCTIVITY BETWEEN C-MOS-LSI AND LIQUID CRYSTAL PANEL</p> <p>Check the liquid crystal panel electrode, connector and lead terminals for contamination and dust. There should be no defect, scratches and damage.</p> <p>LIQUID CRYSTAL PANEL AND CIRCUIT BLOCK</p> <p>Referring to the "Relationship between the segments (Liquid crystal panel electrodes) and C-MOS-LSI output terminals, check the liquid crystal panel and circuit block.</p> <p>(1) Check to see if the corresponding segment of the liquid crystal panel is displayed.</p> <p>(2) Check the circuit block output.</p>	<p>Display Normal Not display Defective Replace the liquid crystal panel.</p> <p>0.8V or more Normal Less than 0.8V Defective Replace the circuit block.</p>
<p>ALARM FUNCTION</p> <p>(1) Check the contacts of piezo electric element and speaker lead terminal for contamination and the speaker lead terminal for deformation.</p> <p>(2) Measure the up converter coil resistance of the circuit block and check for the broken wire and short circuit. Use the Digital Multi Tester S-840A.</p>	<p>50 ~ 90Ω Normal Less than 50Ω Defective (short circuit) More than 90Ω Defective (broken wire) Replace the circuit block.</p>
<p>COIL BLOCK</p> <p>Use the Digital Multi Tester S-840A. Range to be used: Ω</p>	<p>2.3 ~ 2.8kΩ Normal More than 2.8kΩ Defective (broken wire) Less than 2.3kΩ Defective (short circuit) Replace the coil block.</p>
<p>FUNCTION</p> <p>Check the operation referring to the "Operation.", P. 3.</p>	

VII. PARTS LIST

Cal. Y960 A			
PARTS NO.	PART NAME	PARTS NO.	PARTS NAME
125 755	Train wheel bridge	4259 745	Anti-magnetic shield plate
* 221 755	Center wheel & pinion	4270 745	Battery connection (-)
231 755	Third wheel & pinion	4311 745	Coil lead terminal plate
* 241 765	Fourth wheel & pinion	4313 745	Connector
261 795	Minute wheel	4450 745	Switch lever
* 271 765	Hour wheel	4462 961	Coil block cover
281 755	Setting wheel	* 4510 811	Liquid crystal panel (Silver)
282 795	Clutch wheel	* 4510 812	Liquid crystal panel (Gold)
354 795	Winding stem	4512 745	Liquid crystal panel frame
383 755	Setting lever	4540 745	Liquid crystal panel holder
384 795	Yoke	011 325	Upper hole jewel for fourth wheel
388 795	Setting lever spring	011 547	Lower hole jewel for step rotor
391 755	Train wheel setting lever	011 568	Upper hole jewel for step rotor
491 725	Dial washer	022 247	Setting lever spring screw
701 755	Fifth wheel & pinion	022 247	Train wheel bridge screw
4001 745	Circuit block	022 247	Coil block cover screw
4002 755	Coil block	022 247	Circuit block screw
4146 755	Step rotor	022 247	Anti-magnetic shield plate screw
4225 746	Battery clamp	022 247	Liquid crystal panel holder screw
4239 755	Rotor stator	022 247	Battery clamp screw
4246 745	Coil lead terminal	SEIKO TR920W	} Battery
4246 745	Reset lead terminal	MAXELL SR920W	
4246 746	Speaker lead terminal		

Remarks:

* Center wheel & pinion, Fourth wheel & pinion, Hour wheel

There are two different types as specified below:

Combination:

Type	Center wheel & pinion	Fourth wheel & pinion	Hour wheel
a	221 755	241 765	271 765
b	221 795	241 795	271 795

* Liquid crystal panel

4510 811 (Silver)

4510 812 (Gold)

The type of liquid crystal panel is determined based on the design of case.